

# MusicParts.Com

## Technical Document Distribution

---

|                     |                       |                    |
|---------------------|-----------------------|--------------------|
| <b>Brand:</b>       | <b>ARP</b>            |                    |
| <b>Model</b>        | <b>Solus</b>          |                    |
| <b>Product:</b>     | <b>Synthesizer</b>    |                    |
| <b>Description:</b> | <b>Service Manual</b> | <b>Dated: 1980</b> |

Musicparts Document Number: 39688

TechTips: 0

Pages: 30

Hello,

Welcome to MusicParts.Com, Inc. your online resource for technical documents and service information. This PDF package may contain information, schematics, parts lists, images, engineering changes, previous versions, circuit descriptions, and many other unique features about the product you have chosen. This document was assembled from a variety of sources and is the result of our many years in the music repair business.

TECHTIPS: Unique to Musicparts documents are **TECHTIPS** located in critical areas on the schematics. They contain useful information about that area of the schematic such as common problems that we have found and recommended changes. Not all documents will have TechTips.

NOTE: Large original over-sized drawings will need to be taped together. We feel this is better than reducing them and losing fine details.

VIEWING: This document is utilizing PAGE-ON-DEMAND downloading. This will let you navigate to any page without waiting for the entire file to download.

PRINTING: For the best quality, we highly recommend that when the print dialog appears, please **make sure "shrink oversized pages" is checked.**, otherwise you may cut off the edge of the page. Also please stay online while printing this document to make sure you get all the pages.

Visit us on the web at: <http://www.musicparts.com/>  
Email us at: [customerservice@musicparts.com](mailto:customerservice@musicparts.com)

## **MusicParts.Com Special Notes**

### **Copy Quality Concerns**

PLEASE NOTE: This Package Contains Blueprints

The following documents were taken from rare original factory blueprints which are quite old and faded but are still quite readable. As you know, blueprints are not very sharp but it was the best technology of it's day.

For best results, print them using a laser printer. We use high quality scanning techniques and copy quality will be identical to the originals.

Thank You,  
Musicparts.com

# MusicParts.Com

## Four Sheet Pasteup Guide

17x22" paper size

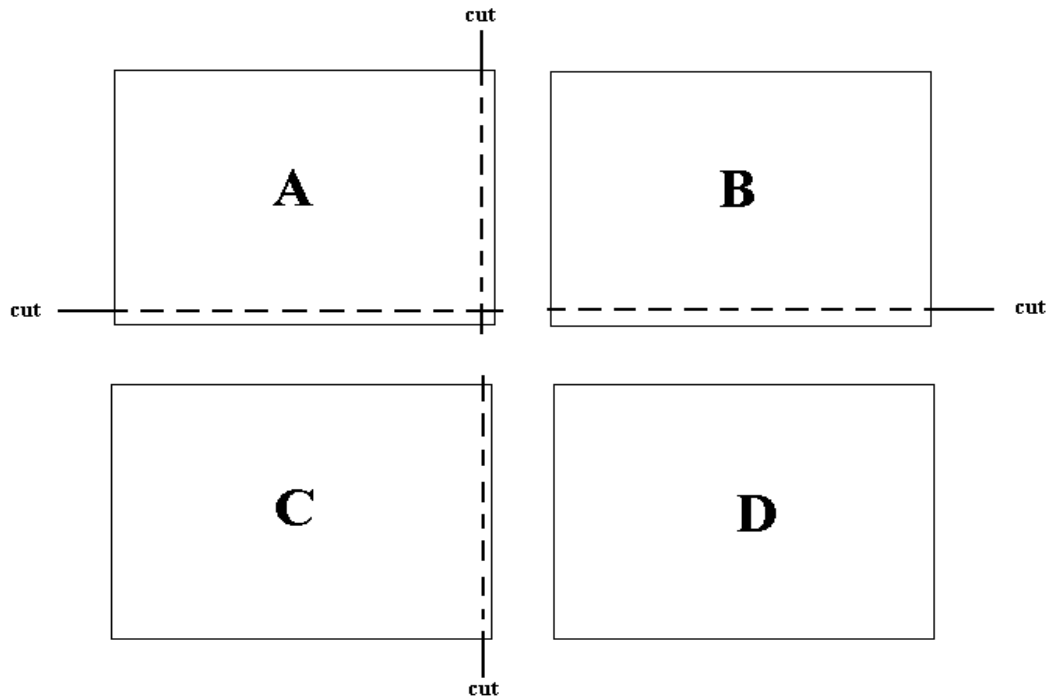

**It's ok to slightly cut into the black print, as documents contain an intentional extended overlapping printed area.**

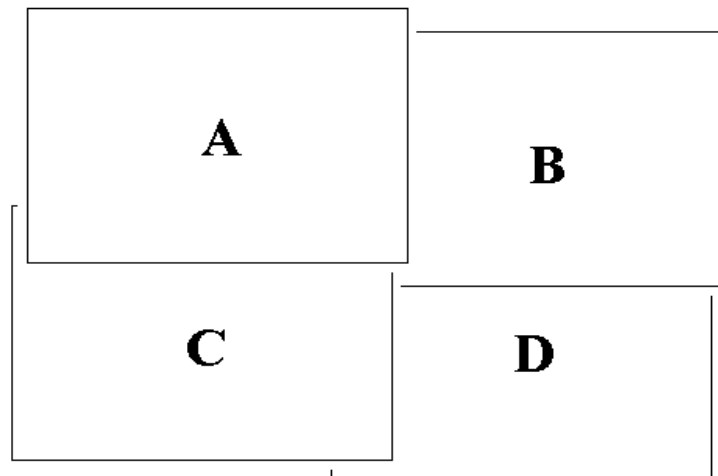

**Only four trim cuts are needed, then overlay as shown and tape**

# ARPSOLUS



**A**s the cost of musical instruments goes up and up, it's unusual to find a lead-line keyboard synthesizer with as many useful live performance features as those to be found on the new ARP Solus. And it's even more unusual to find these features at a price that allows musicians a lot of sound without spending a lot of money.

The Solus delivers the usual array of "human engineered" features, and includes many of the same circuits to be found on more expensive instruments. In a new twist, ARP has created the Solus within its own travelling case, thus adding to the attraction this instrument will certainly have with budget-minded keyboardists.

The Solus incorporates a full

three-octave keyboard. ARP has always maintained the need for a full three octaves for musical reasons and, after all, music is the name of the game. The keyboard can be transposed up or down one octave utilizing the master transposition, or through the use of a VCO 2 transposition allowing for quick setup in live performance, and a very desirable doubling effect over a wide range.

Not one but two oscillators power the Solus. Both VCOs can be phase-synchronized for the classical electronic effects popular with contemporary recording artists, and both feature mixable sawtooth and pulse wave outputs with continuously variable pulsewidth.

The "fat" sound is always asked for by musicians, and the four-pole filter

in the Solus does the trick. Compare the ARP filter in this unit to most other comparably-priced instruments, and you'll hear the difference. The four-pole filter can be modulated with inverted ADSR for extra special effects.

This little instrument has a lot of extras. Where else can you get a ring modulator, phase-synced oscillators, voltage-controlled amplifier (VCA), master vibrato and pitch bend sharp and flat, *plus* a filter pedal input for pedal control (optional) and complete systems interface jacks for interface with other ARP synthesizers, at a price far below what you'd expect. Once again, ARP does a lot with a little.

1. Master Tune: Tunes entire instrument.
2. Transpose: Transposes entire instrument up or down one octave.
3. PWM Source: Selects either the ADSR or LFO sine wave to modulate the pulse width of the square wave.
4. VCO 1 Waveform Mix: Selects either the sawtooth or pulse wave from VCO 1, or a mixture of both.
5. VCO 2: Has its own Tune, Transpose & Waveform Mix controls. The frequency of VCO 2 may also be controlled by the ADSR, or by an optional foot pedal.
6. LFO: Used to produce vibrato, tremolo, and trills.
7. VCF: Changes the timbre of the sound by adding or subtracting harmonics. May be controlled by the LFO, normal or inverted ADSR, the keyboard, or an optional foot pedal for a "wah-wah" effect.
8. Trigger Switch: Selects single or multiple triggering for expressive control, as well as automatic triggering for repetitive effects.
9. ADSR Envelope Generator: Produces articulation parameters ranging from staccato or percussive to gentle or lethargic.
10. Audio Mixer: Permits the use of VCO 1, VCO 2, or a mixture of both. The Ring Modulator allows the mixture of gong and bell-type sounds as well.
11. Portamento: Produces a "sliding" (glissando) effect from one note to the next.
12. Vibrato Depth: Selects the degree of pitch variation, from subtle vibrato to broad, siren-like effects.
13. Pitch Bend: Raises or lowers the pitch of the instrument. Permits "bending" effects, such as those used by guitarists.

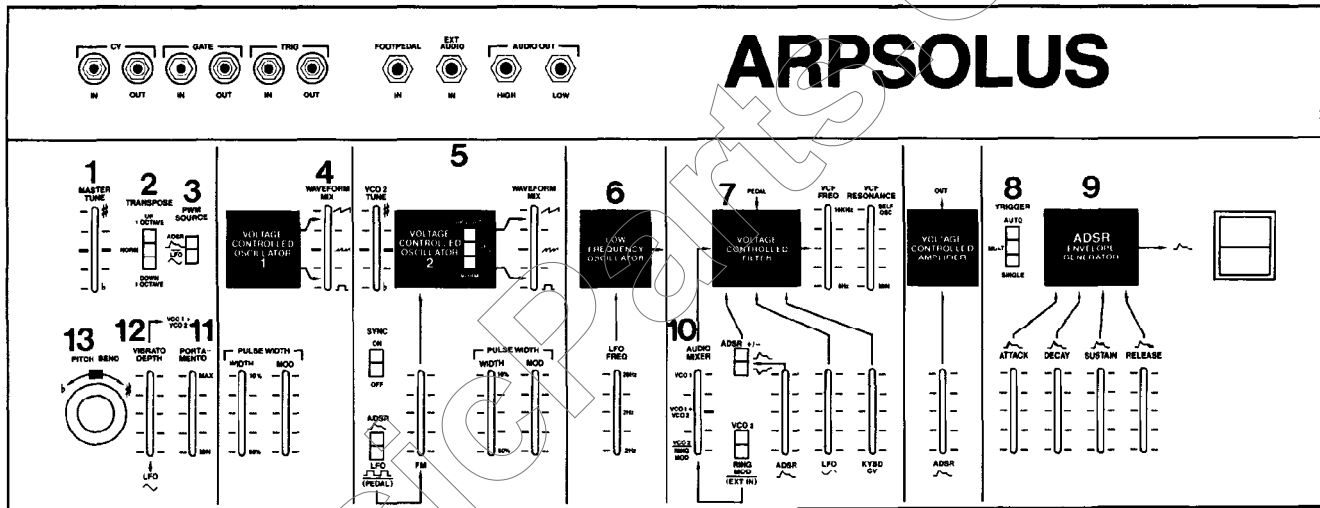

### VOLTAGE CONTROLLED OSCILLATOR

Waveforms: Sawtooth, Pulse (variable pulse width)  
 Frequency Range: 20 Hz to 20 KHz  
 Maximum Frequency Shifts:  
 LFO Square Wave - +1 Octave  
 LFO Sine Wave -  $\pm 2/3$  Octaves  
 ADSR - +7.5 Octaves

### LOW FREQUENCY OSCILLATOR

Waveforms: Sine, Square  
 Frequency Range: 2 Hz to 20 Hz

### VOLTAGE CONTROLLED FILTER

Type: Low Pass  
 Frequency Range: 16 Hz to 16 KHz

### VOLTAGE CONTROLLED AMPLIFIER

Dynamic Range: 57 dB

### ADSR ENVELOPE GENERATOR

Attack Time: 1.3 msec to 1.3 sec  
 Decay Time: 10 msec to 10 sec.  
 Sustain Level: 0 to 100% at peak  
 Release Time: 10 msec to 10 sec.

### AUDIO OUTPUTS

High Level: 2 V PP max., 1 K ohms impedance  
 Low Level: .3 V PP max., 8 K ohms impedance  
 External Audio In: 6 V PP max., 68 K ohms impedance

### INTERFACE JACKS

CV In/Out: 1V/Oct., 5 K ohms impedance (IN)  
 330 ohms impedance (OUT)  
 Gate Out: +12 V - key down, 15 K ohms impedance  
 Gate In: +1 V pulse min., 470 K ohms impedance  
 Trigger Out: +12 V pulse, 100 msec duration, 4.7 ohms impedance  
 Trigger In: +2.8 V min., 15 msec duration min., 120 K ohms impedance

### GENERAL

Height: 6.5"  
 Width: 25"  
 Depth: 16"  
 Weight: 22 lbs

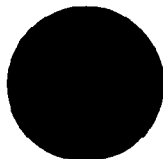

ARP Instruments, Inc  
 45 Hartwell Avenue  
 Lexington, MA 02173

© ARP Instruments, Inc

| REV | DESCRIPTION         | DATE     | APP'D |
|-----|---------------------|----------|-------|
| 7   | 5/23/57 - SEC. 452A | 12/13/57 | NAK   |

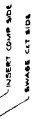
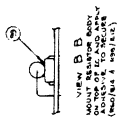
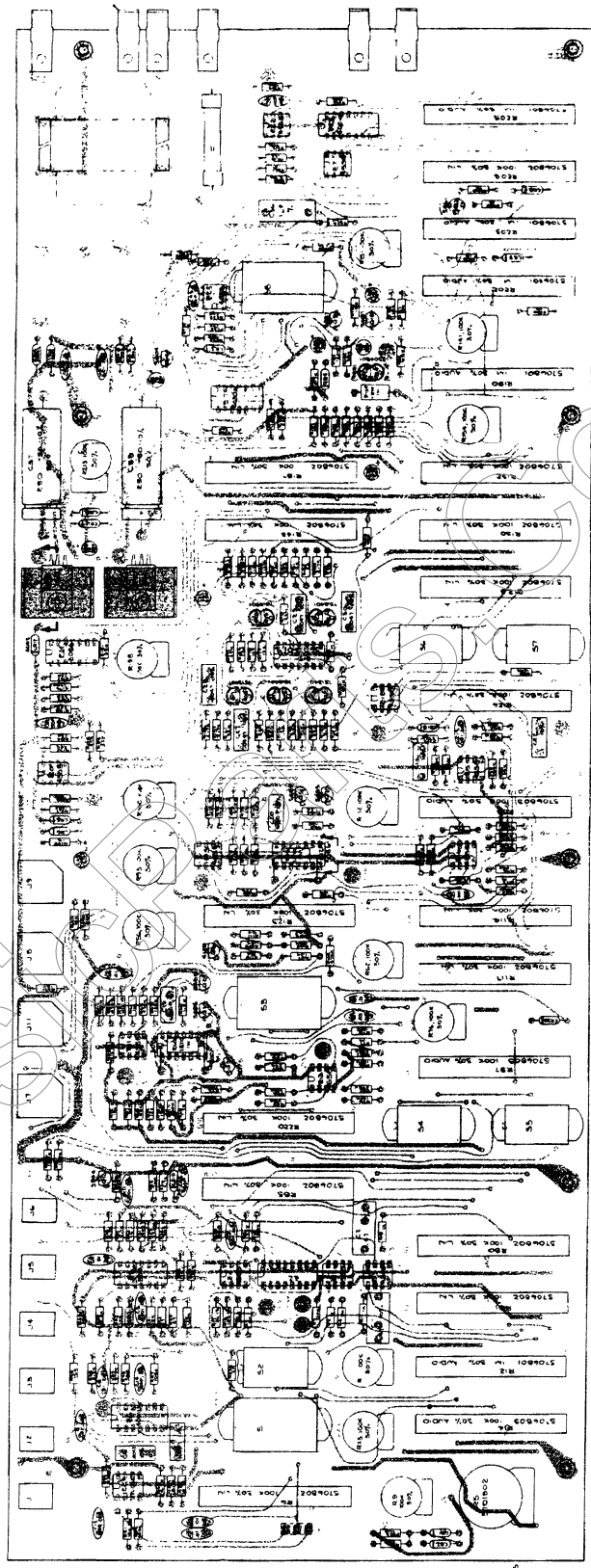
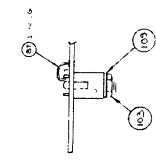
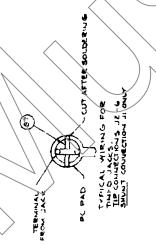
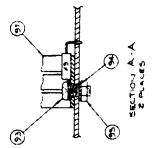
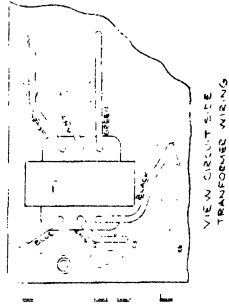

- NOTES:
1. UNLESS OTHERWISE SPECIFIED, ALL RESISTOR VALUES ARE IN OHMS (40% 5%) ALL CAPACITOR VALUES ARE IN  $\mu$ F (20% TOLERANCE)
  2. ALL DIODES ARE 4148
  3. BEND DOWN PIN 1 & ITS DIAGONAL COUNTERPART ON ALL IC'S
  4. FINISHED ASSY TO BE FREE OF EXCESS FLUX
  5. FOR PARTS LIST SEE PL1214901

| REV | DESCRIPTION | DATE     | APP'D |
|-----|-------------|----------|-------|
| 1   | 1224901     | 12/24/57 | NAK   |

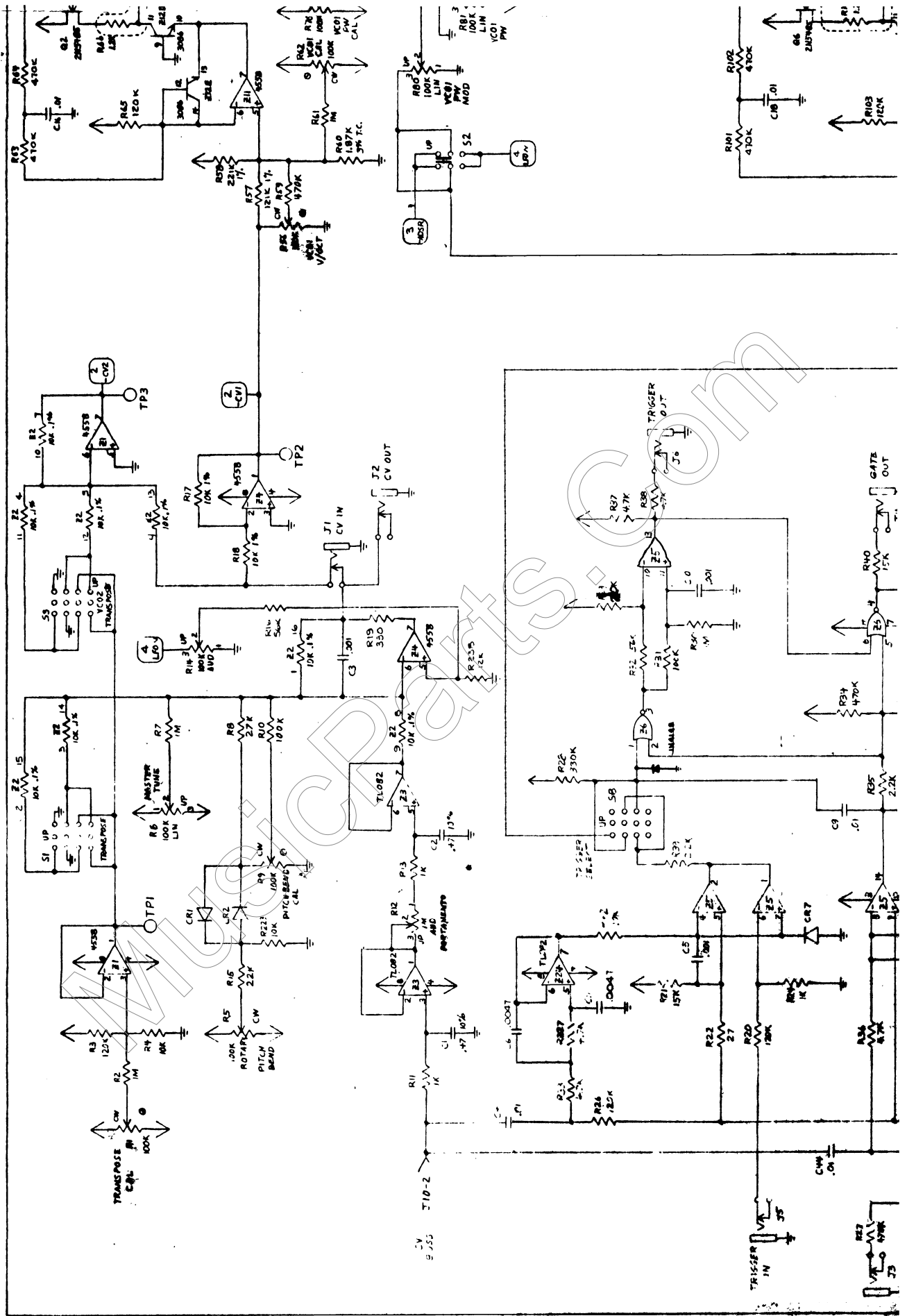

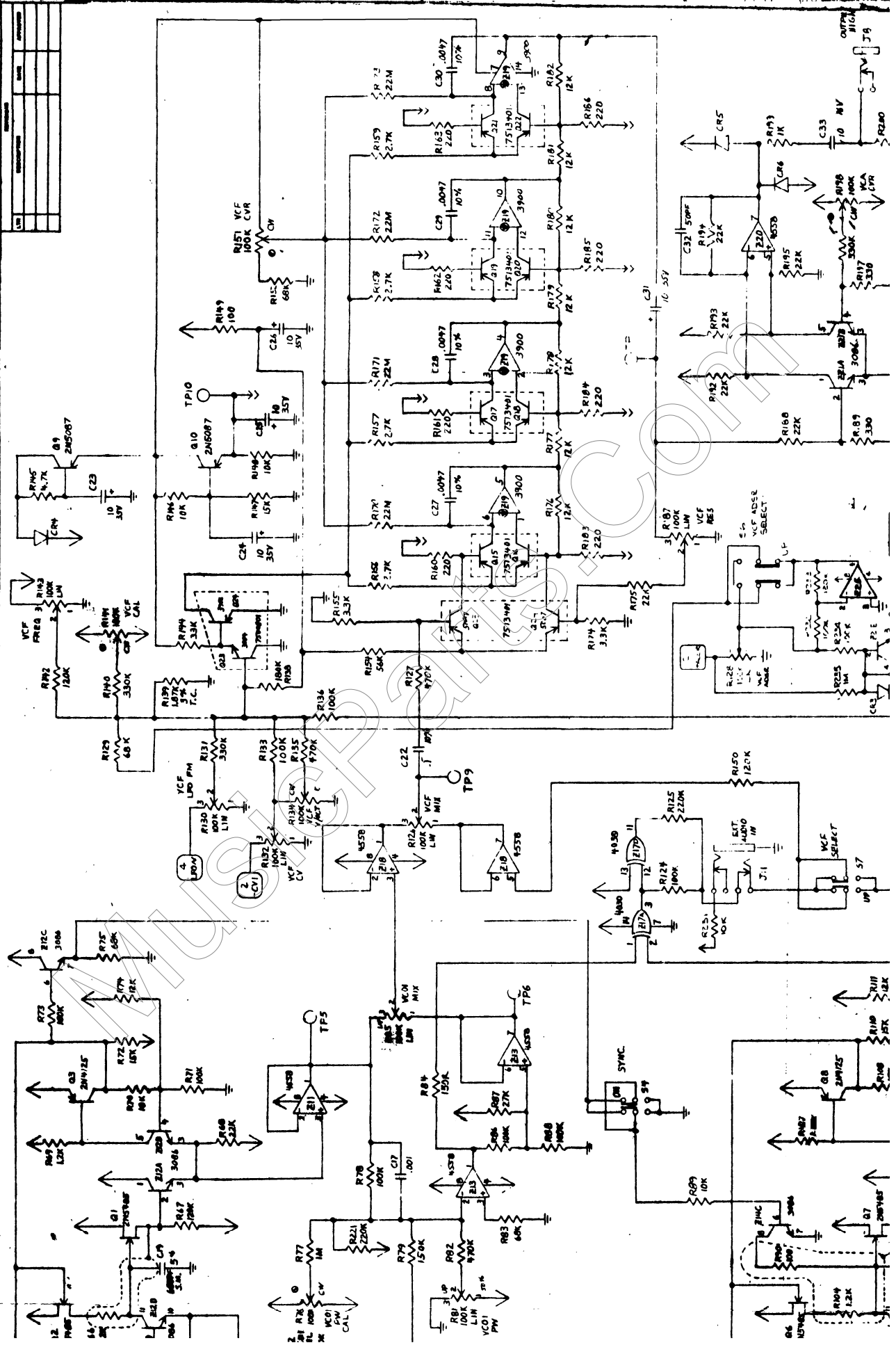

| REV | DESCRIPTION | DATE | BY |
|-----|-------------|------|----|
|     |             |      |    |
|     |             |      |    |
|     |             |      |    |
|     |             |      |    |



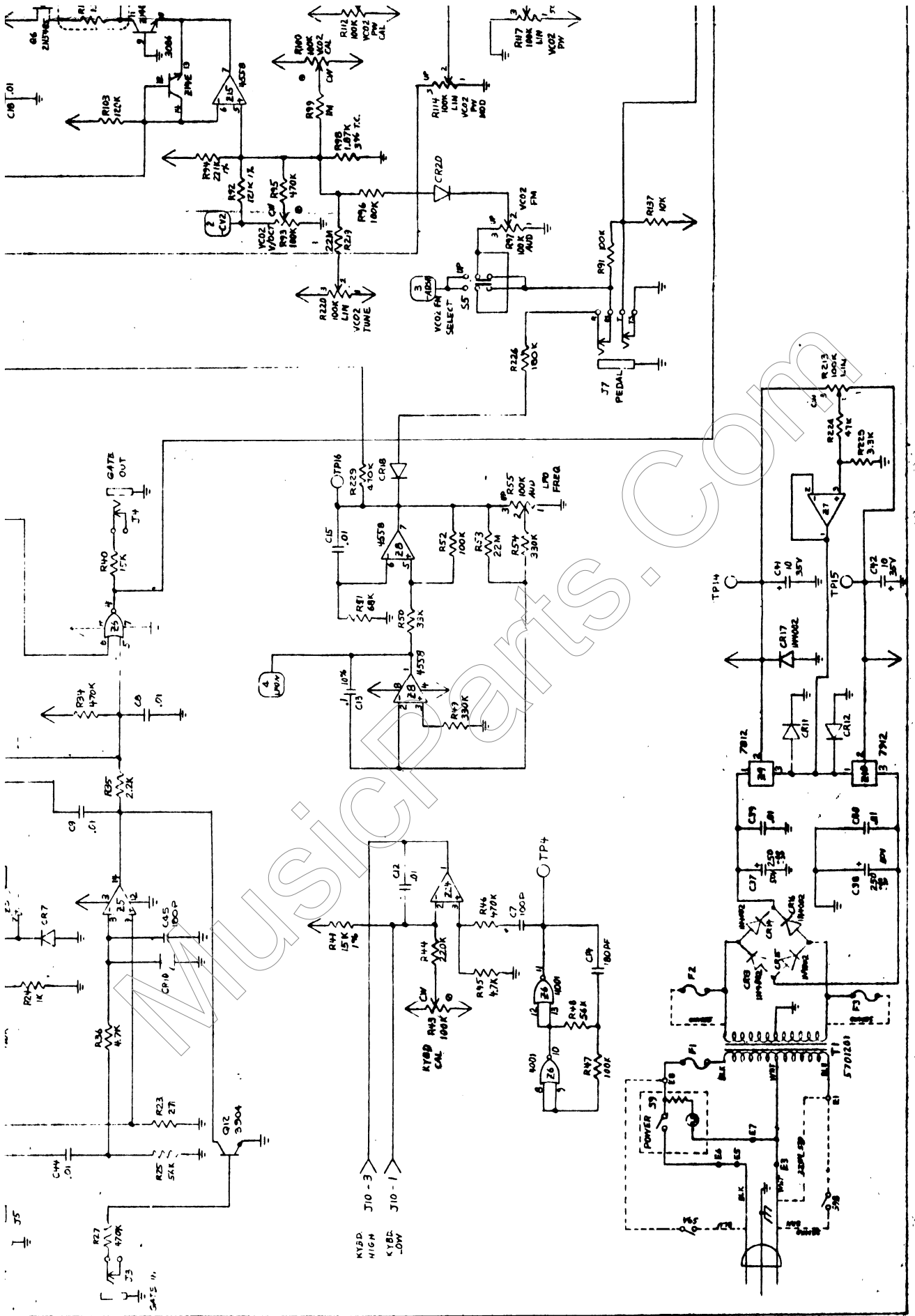

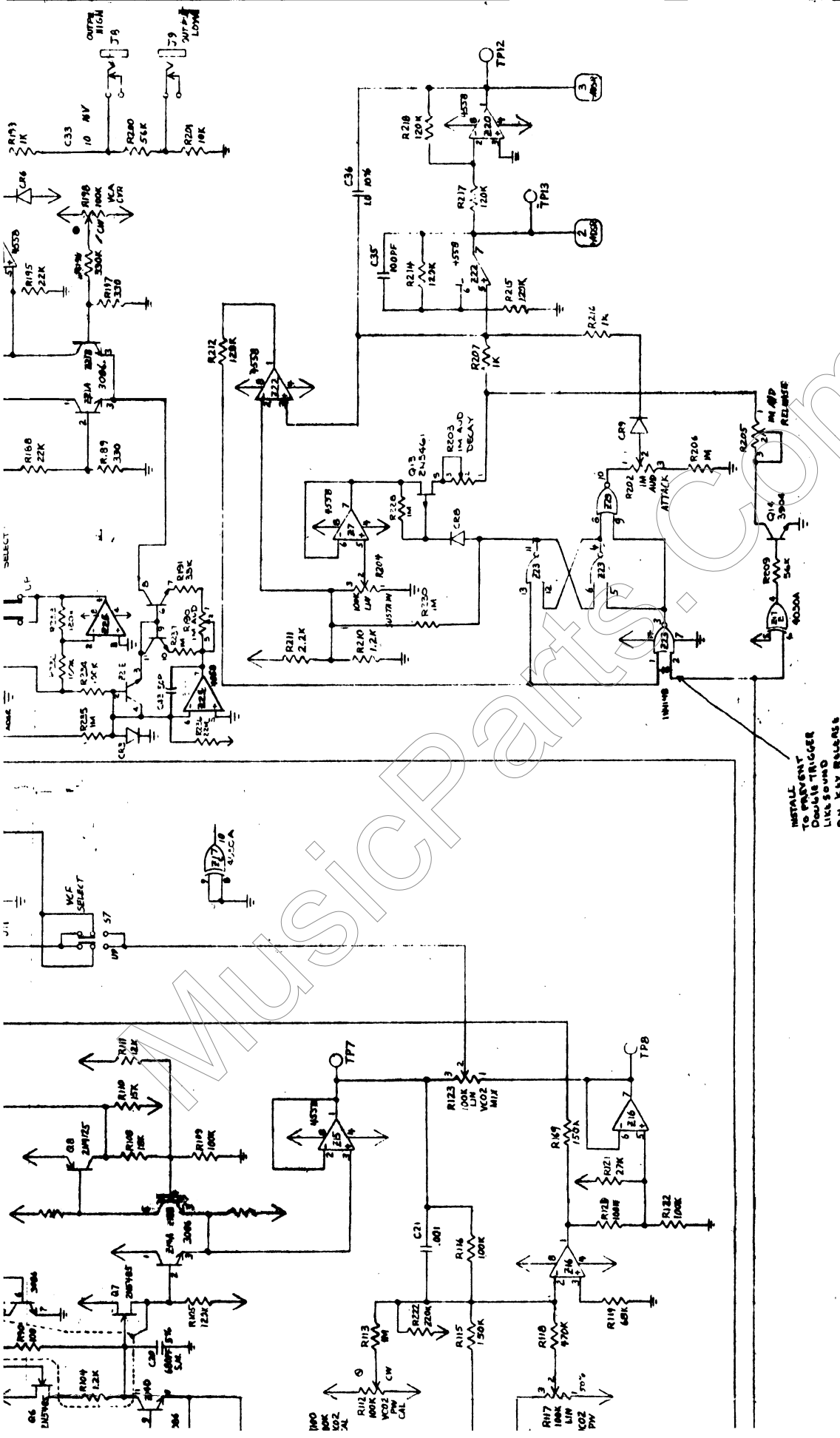

|                 |         |
|-----------------|---------|
| GARP            |         |
| SCHEMATIC 50116 |         |
| REV             | DATE    |
| 1               | 5-21-77 |
| 2               |         |
| 3               |         |
| 4               |         |
| 5               |         |
| 6               |         |

INSTALL TO PREVENT DOUBLE TRIGGER LIKE SOUND ON KEY RELEASE

# ARPSOLUS

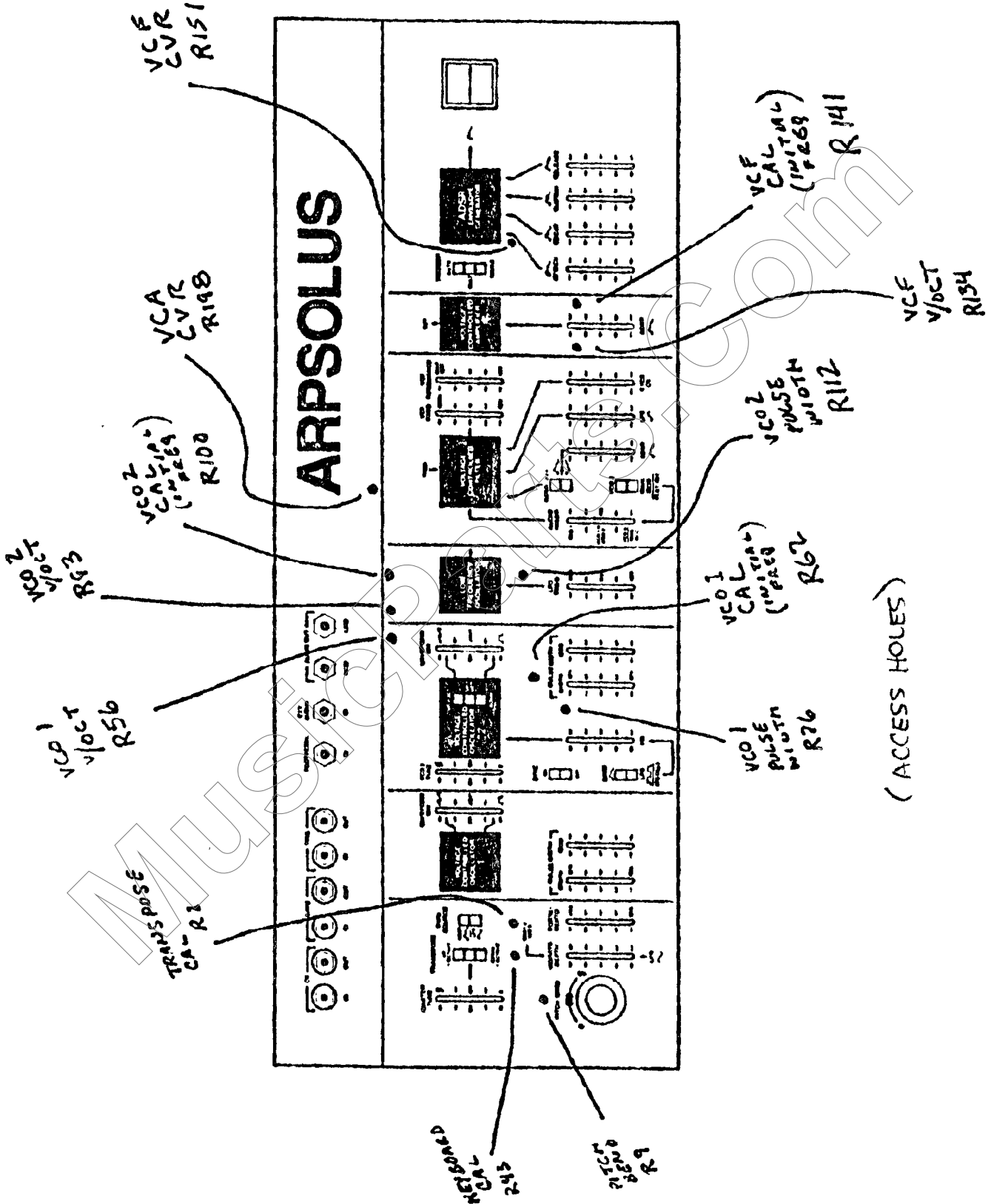



# ARPSOLUS

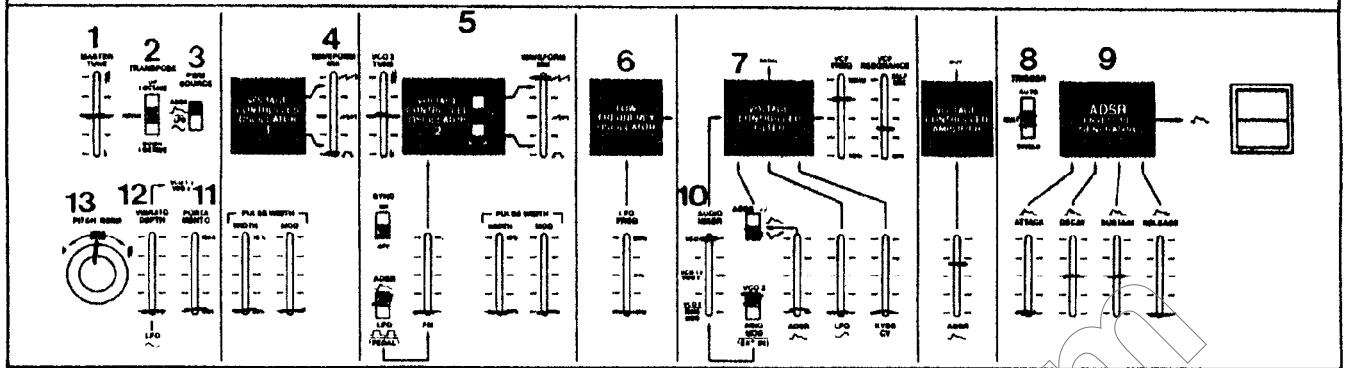

## Ac wiring

- E7 Red wire from switch
- E3 White wire from Ac cord
- E8 white wire from switch
- E5 Black wire from Ac cord
- E6 Black wire from switch

TP1 1 volt Dc

TP2 Low C About 1 volt Dc  
High C " -1.8 volt Dc

TP3 Low C About .1 volt Dc  
high C About -2.7 volt Dc

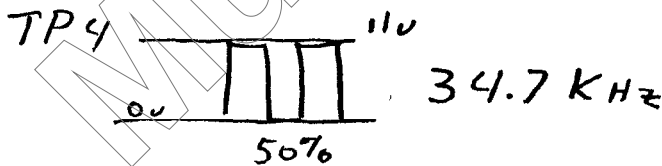

Does not change

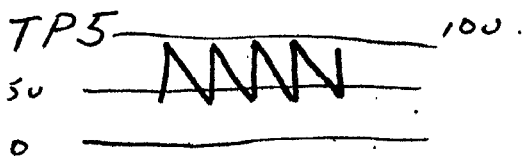

1KHz  
Low C) changes with note played

TP 6

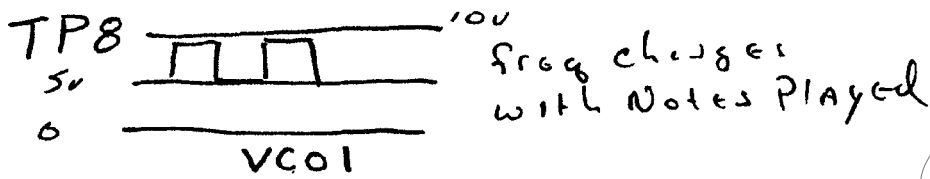
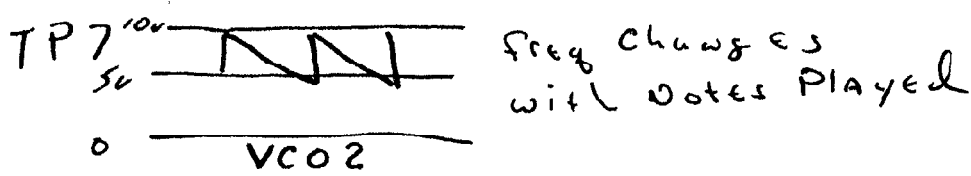

TP9 Shows Mixer Output

TP10 - 5 volts DC

TP11 can be a sine wave changes with position of VCF freq + Resonance

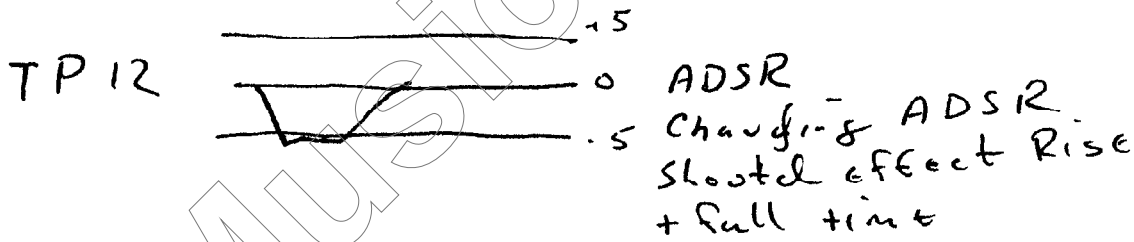

TP13

TP14 +12 vdc

TP15 -12 vdc

TP16 +10 to -10 vdc  
RATE OF LFO  
will change swing

DO IN ORDER OR TOUCH UP ONLY ONES WHICH ARE DEFINITELY OFF CAL.

① KYBD

MONITOR CV OUT WITH DVM  
ADJUST KYBD TRIMMER FOR  
3.00 V HIGHER ON HI C THAN  
ON LO C.

② P.B.

HOLD LO C  
TURN PITCH BEND KNOB FULLY #  
ADJUST P.B. TRIM FOR 1 OCTAVE  
HIGHER.

③ TRAN

LISTEN TO VCO1  
HIT HI C  
FLIP TRANSPOSE SWITCH TO DOWN  
1 OCTAVE  
ADJUST TRAN FOR 1 OCTAVE  
LOWER.

④ VCO1 CAL

SET TRANSPOSE SWITCH TO NORM  
PIN LO C  
CENTER MASTER TUNE SLIDER  
ADJUST VCO1 CAL TO C PITCH

⑤ VCO1 V/OCT

HIT HI C  
ADJUST VCO1 V/OCT FOR 3 OCTAVE  
HIGHER PITCH.  
GO BACK AND FORTH FROM VCO1 CAL  
TO VCO1 V/OCT UNTIL BOTH ARE  
CORRECT.

⑥ VCO1 PW

SET VCO1 WAVEFORM MIX TO  $\square$   
ADJUST VCO1 PW FOR SYMMETRICAL  
WAVEFORM. (PURE CLARINET-LIKE  
SOUND, NO HARSHNESS)

⑦

VCO2 CAL

⑧

VCO2 V/OCT

⑨

VCO2 PW

REPEAT THE ABOVE FOR VCO2.

## 10) VCF CAL

INSERT PHONE PLUG INTO EXT  
AUDIO IN JACK. (USE GUITAR CORD  
AND LEAVE OTHER CORD UNPLUGGED).  
LEAVE IN FOR REST OF CALIBRATIONS.

SET VCF FREQ SLIDER TO  $\frac{1}{4}$   
SET RESONANCE SLIDER UP  
SELECT RING MOD TO THE AUDIO  
MIXER. <sup>R14</sup>  
ADJUST VCF CAL UNTIL FILTER  
JUST BECOMES AN AUDIBLE  
HUM.

CAUTION: THIS IS A ROUGH APPROXIMATION  
THE CORRECT SETTING IS TO  
PULL THE VCF FREQ SLIDER FULLY  
DOWN AND ADJUST FOR 16 HZ.  
BUT YOU CAN'T HEAR THAT LOW.

## 11) VCF V/OCT

RAISE VCF KYBD CV SLIDER.  
LEAVE RESONANCE UP FULLY  
ADJUST VCF FREQ FOR C PITCH  
ON LO C KEY.  
ADJUST VCF V/OCT FOR  $\pm$  OCTAVES  
HIGHER ON HI C

## 12) VCA CVR

RAISE LFO SLIDER  
LOWER VCF FREQ, VCF RESONANCE,  
KYBD CV, AND ADSR SUSTAIN SLIDER.  
SET TRIGGER SWITCH TO AUTO  
ADJUST VCA CVR FOR MINIMUM  
"FLUTTER" ON OUTPUT.

## 13) VCF OVR

RAISE VCF ADSR SLIDER  
ADJUST VCF CVR FOR MINIMUM  
"FLUTTER" ON OUTPUT.

TEST PROCEDURE  
SOLUS, SYSTEM FUNCTIONAL

1. TEST EQUIPMENT REQUIRED:

1.1 6043 SYSTEM TESTER

1.2 OSCILLOSCOPE: TEKTRONIX TYPE 5103N OR EQUIVALENT.

1.2.1 DISPLAY UNIT: TYPE D10 OR EQUIVALENT.

1.2.2 DUAL TRACE AMPLIFIER: TYPE 5A18N OR EQUIVALENT.

1.2.3 TIME BASE/AMPLIFIER: TYPE 5B10N OR EQUIVALENT.

1.3 CABLES:

1.3.1 DUAL BANANA TO MONO PHONE (2 REQUIRED).

1.3.2 DUAL BANANA TO DUAL BANANA

1.3.3 DUMMY PLUG

2. APPLICABLE DRAWINGS:

2.1 SCHEMATIC: SK-1910-77

2.2 PARTS LIST:

2.3 P.C. ASSEMBLY:

|  |  |
|--|--|
|  | ARP<br>INSTRUMENTS<br>INC                    |
| TITLE  | TEST PROCEDURE<br>SOLUS<br>SYSTEM FUNCTIONAL |



### 3. EQUIPMENT SET-UP

- 3.1 SET OSCILLOSCOPE AS FOLLOWS:
  - 3.1.1 CONNECT OSCILLOSCOPE TO 117 VAC.
  - 3.1.2 PULL OSCILLOSCOPE POWER SWITCH OUT (ON).
- 3.2 SET OSCILLOSCOPE DUAL TRACE AMPLIFIER AS FOLLOWS:
  - 3.2.1 SET CH 1 AND CH 2 AC SWITCHES OUT (DC).
  - 3.2.2 SET CH 1 AND CH 2 GND SWITCHES OUT.
  - 3.2.3 SET DISPLAY SWITCH IN (ON).
  - 3.2.4 SET CH 1 AND CH 2 POSITION CONTROL CENTERED UP.
  - 3.2.5 SET CH 1 AND CH 2 MODE SWITCHES IN (ON).
  - 3.2.6 SET CH 1 AND CH 2 VOLTS/DIV SWITCHES TO 5.
  - 3.2.7 SET CH 1 AND CH 2 VOLTS/DIV CAL CONTROL FULLY CLOCKWISE.
  - 3.2.8 SET MODE ADD SWITCH OUT (OFF).
  - 3.2.9 SET CH 1 TRIGGER SWITCHES IN (ON).
  - 3.2.10 SET CH 2 INVERT SWITCH OUT (OFF).
- 3.3 SET OSCILLOSCOPE TIME BASE/AMPL. AS FOLLOWS:
  - 3.3.1 POSITION CONTROL CENTERED UP.
  - 3.3.2 SECONDS/DIV SWITCH TO 1m.
  - 3.3.3 SET SECONDS/DIV CAL CONTROL FULLY CLOCKWISE.
  - 3.3.4 SET DISPLAY CHOP SWITCH OUT (ALT).
  - 3.3.5 SET SWP MAG SWITCH OUT (OFF).
  - 3.3.6 SET LEVEL CONTROL CENTERED UP.
  - 3.3.7 SET TRIGGERING SOURCE LEFT SWITCH IN (ON).
  - 3.3.8 SET TRIGGERING SOURCE RIGHT SWITCH OUT (OFF).
  - 3.3.9 SET TRIGGERING SOURCE LINE SWITCH OUT (OFF).
  - 3.3.10 SET TRIGGERING SOURCE EXT SWITCH OUT (OFF).
  - 3.3.11 SET TRIGGERING AUTO TRIG SWITCH IN ( ).
  - 3.3.12 SET TRIGGERING AC COUPLE SWITCH OUT (DC).
  - 3.3.13 SET TRIGGERING + SLOPE SWITCH IN (+).
  - 3.3.14 SET TRIGGERING SINGLE SWP SWITCH OUT (OFF).
- 3.4 ADJUST OSCILLOSCOPE INTENSITY CONTROL FOR REASONABLE TRACE BRILLIANCE.
- 3.5 ADJUST OSCILLOSCOPE FOCUS CONTROL FOR TRACE SHARPNESS.

- 3.6 READJUST TIME BASE/AMPL. POSITION CONTROL TO START TRACES AT THE LEFT GRATICULE LINE.
- 3.7 READJUST BOTH DUAL-TRACE AMPLIFIER POSITION CONTROLS TO CENTER TRACES VERTICALLY.
- 3.8 SET MODE CH 2 SWITCH OUT (OFF).
- 3.9 CONNECT DUAL BANANA TO DUAL BANANA CABLE FROM OSCILLOSCOPE CH 1 TO TEST SET OUTPUT LABELED SCOPE (OBSERVING POLARITY OF BANANA PLUGS).
- 3.10 SET TEST SET AS FOLLOWS:
  - 3.10.1 SET POWER SWITCH OFF.
  - 3.10.2 CONNECT LINE CORD TO 117 VAC.
  - 3.10.3 SET EARPHONE VOL CONTROL CCW.
  - 3.10.4 SET METER SELECT SWITCH 1CV-C2
  - 3.10.5 CONNECT MONO PHONE PLUG TO DUAL BANANA CABLE ASSEMBLY TO LOW LEVEL INPUT JACKS (OBSERVING POLARITY OF BANANA PLUGS).
  - 3.10.6 CONNECT EARPHONES TO EARPHONE INPUT JACK.
  - 3.10.7 CONNECT PHONE PLUG TO DUAL BANANA CABLE TO HIGH LEVEL INPUT JACKS (OBSERVING POLARITY OF BANANA PLUG).
  - 3.10.8 SET OFFSET SWITCH OFF.
  - 3.10.9 SET VOLT/FREQ SWITCH TO VOLT.
  - 3.10.10 SET POWER SWITCH ON.

#### 4. PRELIMINARY SET-UP

- 4.1 INSPECT UNIT UNDER TEST (HEREINAFTER CALLED U.U.T.) FOR ELECTROMECHANICAL ASSEMBLY.
- 4.2 SET U.U.T. AS FOLLOWS:
  - 4.2.1 POWER SWITCH OFF.
  - 4.2.2 CONNECT LINE CORD TO APPROPRIATE A.C. VOLTAGE.
  - 4.2.3 CONNECT PHONE PLUG CABLE FROM TEST SET LOW LEVEL INPUT JACK TO U.U.T. LOW OUTPUT JACK.
  - 4.2.4 CONNECT PHONE PLUG CABLE FROM TEST SET HIGH LEVEL TO U.U.T. HIGH OUTPUT JACK.
  - 4.2.5 ALL SLIDER CONTROLS DOWN.
  - 4.2.6 PITCH BEND CONTROL MIDPOSITION.

- 4.2.7 TRANSPOSE SWITCH MIDPOSITION.
- 4.2.8 VCO-2/RING MOD. SWITCH UP.
- 4.2.9 ALL OTHER SWITCHES DOWN.
- 4.2.10 VCF FREQ CONTROL UP.
- 4.2.11 VCA CONTROL UP.
- 4.2.12 ADSR SUSTAIN SLIDER UP.
- 4.2.13 POWER SWITCH ON (RED LAMP SHOULD BE ON).

## 5. MASTER TUNE, PITCH BEND, TRANSPOSE, VIBRATO CHECK:

- 5.1 DEPRESS AND WEDGE DOWN C2 KEY.
- 5.2 USING EARPHONES, ADJUST TEST SET EARPHONE VOL CONTROL TO DESIRED LISTENING LEVEL.
- 5.3 A SQUAREWAVE SHOULD BE HEARD ON EARPHONES AND OBSERVED ON SCOPE.
- 5.4 MOVE MASTER TUNE SLIDER UP.  
SQUAREWAVE SHOULD VARY UP IN FREQUENCY SMOOTHLY.
- 5.5 SET MASTER TUNE SLIDER TO MIDPOSITION.
- 5.6 ROTATE PITCH BEND KNOB CCW TO  $\flat$  (FLAT).  
SQUAREWAVE SHOULD VARY DOWN IN FREQUENCY SMOOTHLY.
- 5.7 ROTATE PITCH BEND KNOB CW TO  $\sharp$  (SHARP).  
SQUAREWAVE SHOULD VARY UP IN FREQUENCY SMOOTHLY.
- 5.8 SET PITCH BEND KNOB TO MIDPOSITION.
- 5.9 SET TRANSPOSE SWITCH UP. SQUAREWAVE SHOULD GO UP ONE OCTAVE.
- 5.10 SET TRANSPOSE SWITCH DOWN. SQUAREWAVE SHOULD GO DOWN ONE OCTAVE.
- 5.11 SET TRANSPOSE SWITCH TO MIDPOSITION.
- 5.12 SET VIBRATO DEPTH SLIDER UP. SQUAREWAVE SHOULD VARY UP AND DOWN IN FREQUENCY SMOOTHLY - CREATING A SIREN EFFECT.
- 5.13 SET VIBRATO DEPTH SLIDER DOWN.

## 6. VCO-2 CHECK :

- 6.1 MOVE VCO-2 TUNE SLIDER UP. SQUAREWAVE SHOULD VARY UP IN FREQUENCY SMOOTHLY.
- 6.2 SET VCO-2 TUNE TO MIDPOSITION.
- 6.3 SET VCO-2 TRANSPOSE TO MIDPOSITION. SQUAREWAVE SHOULD GO UP IN FREQUENCY ONE OCTAVE.
- 6.4 SET VCO-2 TRANSPOSE TO TOP POSITION. SQUAREWAVE SHOULD GO UP IN FREQUENCY ONE MORE OCTAVE.
- 6.5 SET VCO-2 TRANSPOSE TO NORM.
- 6.6 SET VCO-2 FM SLIDER UP. SQUAREWAVE SHOULD BE ALTERNATING BETWEEN THE ORIGINAL FREQUENCY AND A HIGHER FREQUENCY.
- 6.7 SET LFO FREQ. UP. THE SPEED OF THE ALTERNATING FREQUENCIES SHOULD INCREASE.
- 6.8 SET LFO FREQ. TO MIDPOSITION.
- 6.9 SET VCO-2 FM SWITCH TO ADSR. SQUAREWAVE SHOULD DISAPPEAR.
- 6.10 SLOWLY MOVE VCO-2 FM SLIDER DOWN. SQUAREWAVE SHOULD REAPPEAR AND SHOULD BE DECREASING IN FREQUENCY SMOOTHLY.
- 6.11 SET VCO-2 FM SLIDER UP TO 3<sup>RD</sup> GRADUATION.
- 6.12 SET SYNC SWITCH TO ON. WAVEFORM ON SCOPE SHOULD BE SIMILAR TO FIG. 1 (NOTE: A SLIGHT ADJUSTMENT OF VCO-2 FM SLIDER UP OR DOWN MAY BRING THIS WAVEFORM IN A LITTLE CLEARER)

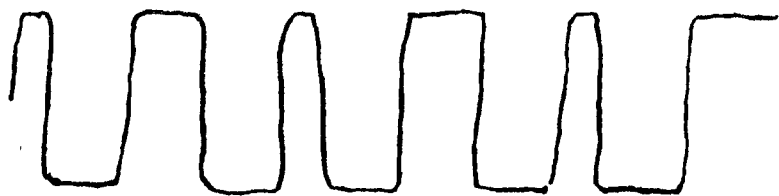

FIG. 1

- 6.13 SET SYNC SWITCH TO OFF.
- 6.14 SET VCO-2 FM SLIDER DOWN.
- 6.15 SET VCO-2 PULSE WIDTH SLIDER UP. WIDTH OF DUTY CYCLE SHOULD VARY SMOOTHLY FROM 2 HORIZONTAL DIVISIONS TO APPROXIMATELY .5 HORIZONTAL DIVISIONS ON SC.
- 6.16 SET VCO-2 PULSE WIDTH SLIDER DOWN. WIDTH OF DUTY CYCLE SHOULD RETURN TO 2 HORIZONTAL DIVISIONS
- 6.17 SET LFO FREQ. SLIDER AT 2<sup>ND</sup> GRADUATION.
- 6.18 SET VCO-2 PULSE WIDTH MOD SLIDER UP. WIDTH OF DUTY CYCLE SHOULD BE VARYING SMOOTHLY BETWEEN .5 HORIZONTAL DIVISIONS AND 3.5 HORIZ. DIV.
- 6.19 SET VCO-2 PULSE WIDTH MOD SLIDER DOWN. WIDTH OF DUTY CYCLE SHOULD BE 2 HORIZONTAL DIVISIONS
- 6.20 MOVE VCO-2 WAVEFORM MIX SLIDER UP SLOWLY AND OBSERVE ON SCOPE THE SQUAREWAVE CHANGE TO SAWTOOTH.

## 7. AUDIO MIXER, VCO-1 CHECK :

- 7.1 SET AUDIO MIXER VCO-2/RING MOD SWITCH DOWN. SAWTOOTH SHOULD CHANGE TO A RING MODULATED SQUAREWAVE.
- 7.2 SET AUDIO MIXER VCO-2/RING MOD SWITCH UP. RING MOD SHOULD CHANGE BACK TO A SAWTOOTH.
- 7.3 MOVE AUDIO MIXER SLIDER UP SLOWLY AND NOTICE THE SAWTOOTH MIXING WITH A SQUAREWAVE AND FINALLY TO A FULL SQUAREWAVE.
- 7.4 SET VCO-1 PULSE WIDTH SLIDER UP. WIDTH OF DUTY CYCLE SHOULD VARY SMOOTHLY FROM 2 HORIZONTAL DIVISIONS TO APPROXIMATELY .5 HORIZONTAL DIV. ON SCOPE.
- 7.5 SET VCO-1 PULSE WIDTH SLIDER DOWN. WIDTH OF DUTY CYCLE SHOULD RETURN TO 2 HORIZ. DIV.
- 7.6 SET VCO-1 PULSE WIDTH MOD SLIDER UP. WIDTH OF DUTY CYCLE SHOULD BE VARYING SMOOTHLY BETWEEN .5 HORIZ. DIV. AND 3.5 HORIZ. DIV.

- 7.7 SET PWM SOURCE SWITCH UP. WAVEFORM ON SCOPE SHOULD BE SIMILAR TO FIG. 2



FIG. 2

- 7.8 SET VCO-1 PULSE WIDTH MOD SLIDER DOWN. WAVEFORM ON SCOPE SHOULD RETURN TO SQUAREWAVE.
- 7.9 MOVE VCO-1 WAVEFORM MIX SLIDER UP SLOWLY AND OBSERVE ON SCOPE THE SQUAREWAVE CHANGE TO A SAWTOOTH
- 7.10 SET ADSR SUSTAIN SLIDER DOWN. SAWTOOTH SHOULD DISAPPEAR.

## 8. TRIGGER

- 8.1 SET ADSR DECAY SLIDER TO THE 2<sup>ND</sup> GRADUATION.
- 8.2 DEPRESS AND RELEASE C3. THERE SHOULD BE NO OUTPUT.
- 8.3 DEPRESS AND RELEASE C1. THERE SHOULD BE NO OUTPUT.
- 8.4 SET TRIGGER SWITCH TO MULT.
- 8.5 DEPRESS AND RELEASE C3. THERE SHOULD BE NO OUTPUT.
- 8.6 DEPRESS C1. A LOW FREQUENCY OUTPUT OF SHORT DURATION SHOULD APPEAR.
- 8.7 RELEASE C1. A HIGHER FREQUENCY OUTPUT OF SHORT DURATION SHOULD APPEAR.
- 8.8 SET TRIGGER SWITCH TO AUTO. SAME FREQUENCY AS IN STEP 8.7 OF SHORT DURATION SHOULD BE REPEATING.
- 8.9 SET TRIGGER SWITCH TO MULT. THERE SHOULD BE NO OUTPUT.
- 8.10 REMOVE WEDGE ON C2. NO OUTPUT
- 8.11 SET ADSR DECAY SLIDER DOWN.

- 8.12 SET ADSR ATTACK SLIDER UP.
- 8.13 DEPRESS AND HOLD C2. SAWTOOTH SHOULD APPEAR AND RISE SLOWLY TO A PEAK AND DISAPPEAR QUICKLY.  
RELEASE C2.
- 8.14 SET ADSR ATTACK SLIDER DOWN.
- 8.15 SET ADSR DECAY SLIDER UP. THERE SHOULD BE NO OUTPUT.
- 8.16 DEPRESS AND HOLD C2. SAWTOOTH SHOULD PEAK QUICKLY AND SLOWLY DISAPPEAR.  
RELEASE C2.
- 8.17 SET ADSR DECAY SLIDER DOWN.
- 8.18 SET ADSR SUSTAIN SLIDER UP. THERE SHOULD BE NO OUTPUT.
- 8.19 DEPRESS AND HOLD C2. SAWTOOTH SHOULD PEAK QUICKLY AND REMAIN PEAKED.
- 8.20 RELEASE C2. SAWTOOTH SHOULD DISAPPEAR QUICKLY.
- 8.21 SET ADSR RELEASE SLIDER UP. THERE SHOULD BE NO OUTPUT.
- 8.22 DEPRESS AND RELEASE C2. SAWTOOTH SHOULD PEAK QUICKLY AND SLOWLY DISAPPEAR.
- 8.23 SET RELEASE SLIDER DOWN.
- 8.24 DEPRESS AND WEDGE DOWN C4. A STEADY, HIGH FREQUENCY SAWTOOTH SHOULD APPEAR.
- 8.25 SET PORTAMENTO SLIDER UP. THERE SHOULD BE NO CHANGE IN FREQ.
- 8.26 DEPRESS AND HOLD C1. SAWTOOTH SHOULD GLIDE SLOWLY AND SMOOTHLY TO THE FREQUENCY AT C1.
- 8.27 SET PORTAMENTO SLIDER DOWN.
- 8.28 RELEASE C1. SAWTOOTH SHOULD CHANGE SHARPLY TO C4.
- 8.29 MOVE VCA ADSR (VOLTAGE CONTROLLED AMPLIFIER) SLIDER DOWN SLOWLY, AMPLITUDE OF SAWTOOTH SHOULD DECREASE UNTIL BARELY AUDIBLE.
- 8.30 SET VCA ADSR SLIDER UP. SAWTOOTH SHOULD RETURN TO FULL AMPLITUDE.
- 8.31 REMOVE WEDGE ON C4. THERE SHOULD BE NO OUTPUT.

## 9. VCF CHECK:

- 9.1 INSTALL DUMMY PLUG INTO EXT. AUDIO IN JACK,
- 9.2 SET AUDIO MIXER VCO-2/RING MOD SWITCH DOWN,
- 9.3 SET AUDIO MIXER SLIDER DOWN,
- 9.4 SET VCF RESONANCE SLIDER UP.
- 9.5 SET ADSR SUSTAIN SLIDER DOWN,
- 9.6 SET ADSR ATTACK AND DECAY SLIDERS UP.
- 9.7 SET VCF ADSR SLIDER UP.
- 9.8 DEPRESS AND HOLD ANY KEY. A SINEWAVE GLIDING SMOOTHLY FROM A HIGH FREQ. DOWN TO A LOW FREQ. AND BACK UP TO A HIGH FREQ. SHOULD APPEAR. RELEASE KEY. THERE SHOULD BE NO OUTPUT.
- 9.10 SET ADSR +/- SWITCH UP.
- 9.11 SET VCF FREQ SLIDER DOWN.
- 9.12 DEPRESS AND HOLD ANY KEY. A SINEWAVE GLIDING SMOOTHLY FROM A LOW FREQ. UP TO A HIGH FREQ. AND BACK DOWN TO A LOW FREQ. SHOULD APPEAR. RELEASE KEY.
- 9.13 SET VCF ADSR SLIDER DOWN,
- 9.14 SET ADSR ATTACK AND DECAY SLIDERS DOWN,
- 9.15 SET ADSR SUSTAIN SLIDER UP,
- 9.16 SET VCF LFO SLIDER UP.
- 9.17 SET VCF FREQ. TO 3<sup>RD</sup> GRADUATION,
- 9.18 SET LFO FREQ. TO 3<sup>RD</sup> GRADUATION,
- 9.19 DEPRESS AND HOLD ANY KEY. A SINEWAVE GLIDING UP AND DOWN SMOOTHLY SHOULD APPEAR (SIREN EFFECT).
- 9.20 RELEASE KEY.
- 9.21 SET VCF LFO SLIDER DOWN,
- 9.22 SET VCF KYBD CV SLIDER UP.
- 9.23 SUCCESSIVELY DEPRESS AND RELEASE C1, C2, C3 AND C4 SINEWAVE FREQUENCY SHOULD TRACK KEYBOARD; ONE OCTAVE AT A TIME.



## 10. KEYBOARD CHECK :

- 10.1 SET AUDIO MIXER VCO-2/RING MOD SWITCH UP.
- 10.2 SET VCF ADSR SLIDER UP.
- 10.3 SET VCF FREQ SLIDER DOWN.
- 10.4 SET VCF RESONANCE SLIDER DOWN.
- 10.5 SET ADSR SUSTAIN SLIDER DOWN.
- 10.6 SET ADSR DECAY SLIDER TO 2<sup>ND</sup> GRADUATION.
- 10.7 SET VCO-2 WAVEFORM MIX DOWN.
- 10.8 DEPRESS AND HOLD C4.
- 10.9 STARTING WITH C1 AND WORKING UP THE KEYBOARD IN SUCCESSION, PRESS EACH KEY SLOWLY FOUR OR FIVE TIMES. THE TONE PRODUCED SHOULD BE CLEAN AND SMOOTH. IF ANY NOTE BREAKS UP OR PLAYS C4 FIRST, CLEAN OR ADJUST THE KEY CONTACTS AS NECESSARY.

## 11. SHUTDOWN:

- 11.1 SET U.U.T. POWER SWITCH OFF.
- 11.2 REMOVE CABLE FROM U.U.T. LOW OUTPUT JACK.
- 11.3 REMOVE CABLE FROM U.U.T. HIGH OUTPUT JACK.
- 11.4 REMOVE U.U.T. LINE CORD FROM A.C. OUTLET.
- 11.5 MARK U.U.T. WITH PROPER DISPOSITION.

# TEST PROCEDURE SOLUS FINAL TUNE

## 1. TEST EQUIPMENT REQUIRED:

- 1.1 TEST SET: SYSTEM TEST SET 6043
- 1.2 OSCILLOSCOPE: TEKTRONIX TYPE 5103N OR EQUIVALENT.
  - 1.2.1 DISPLAY: TYPE D10 OR EQUIVALENT.
  - 1.2.2 DUAL TRACE AMPLIFIER: TYPE 5A18N OR EQUIVALENT.
  - 1.2.3 TIME BASE/AMPLIFIER: TYPE 5B10 OR EQUIVALENT.
- 1.3 CABLES:
  - 1.3.1 2BC-BNC-36
  - 1.3.2 36" BANANA TO BALL CLIP LEAD, RED.
  - 1.3.3 36" BANANA TO BALL CLIP LEAD, BLACK.
  - 1.3.4 DUAL BANANA TO PHONE (2 REQUIRED)
  - 1.3.5 TINY D TO TINY D
  - 1.3.6 DUMMY PHONE PLUG

## 2. APPLICABLE DRAWINGS:

- 2.1 SCHEMATIC: SK-1910-77
- 2.2 PC ASSEMBLY:
- 2.3 PARTS LIST: 72249

|           |             |      |      |   |  |   |                           |
|-----------|-------------|------|------|---|--|---|---------------------------|
|           |             |      |      | ARP PART NO   |  |   |                           |
|           |             |      |      |  | PROCUREMENT<br>DRAWING                         |   | ARP<br>INSTRUMENTS<br>INC |
|           |             |      |      |   | TITLE<br>TEST PROCEDURE<br>FINAL TUNE<br>SOLUS |   |                           |
|           |             |      |      | DRAWN   |  | SYM PD    SIZE A    DRAWING NO 81110    REV A |                           |
|           |             |      |      | CHECKED   |  |   |                           |
|           |             |      |      | APPROVED  |  | SHEET 1 OF 9                                  |                           |
|           |             |      |      | APPROVED  |  |   |                           |
| REV       | DESCRIPTION | DATE | APPD | APPROVED  |  |   |                           |
| REVISIONS |             |      |      |   |  |   |                           |

## FINAL TUNE

### 3. EQUIPMENT SETUP:

- 3.1 SET OSCILLOSCOPE AS FOLLOWS:
  - 3.1.1 CONNECT OSCILLOSCOPE TO 117 VAC.
  - 3.1.2 PULL OSCILLOSCOPE POWER SWITCH OUT (ON).
- 3.2 SET OSCILLOSCOPE DUAL-TRACE AMPLIFIER AS FOLLOWS:
  - 3.2.1 SET CH 1 AND CH 2 AC SWITCHES OUT (DC).
  - 3.2.2 SET CH 1 AND CH 2 GND SWITCHES OUT.
  - 3.2.3 SET DISPLAY SWITCH IN (ON).
  - 3.2.4 SET CH 1 AND CH 2 POSITION CONTROLS CENTERED UP.
  - 3.2.5 SET CH 1 AND CH 2 MODE SWITCHED IN (ON).
  - 3.2.6 SET CH 1 AND CH 2 VOLTS/DIV SWITCHES TO .2
  - 3.2.7 SET CH 1 AND CH 2 VOLTS/DIV CAL CONTROL FULLY CLOCKWISE.
  - 3.2.8 SET MODE ADD SWITCH OUT (OFF).
  - 3.2.9 SET CH 1 AND CH 2 TRIGGER SWITCHES IN (ON).
  - 3.2.10 SET CH 2 INVERT SWITCH OUT (OFF).
- 3.3 SET OSCILLOSCOPE TIME BASE/AMPL. AS FOLLOWS:
  - 3.3.1 POSITION CONTROL CENTERED UP.
  - 3.3.2 SECONDS/DIV SWITCH TO .2M.
  - 3.3.3 SET SECONDS/DIV CAL CONTROL FULLY CLOCKWISE.
  - 3.3.4 SET DISPLAY CHOP SWITCH IN (CHOP).
  - 3.3.5 SET SWP MAG SWITCH OUT (OFF).
  - 3.3.6 SET LEVEL CONTROL CENTERED UP.
  - 3.3.7 SET TRIGGERING SOURCE LEFT SWITCH IN (ON).
  - 3.3.8 SET TRIGGERING SOURCE RIGHT SWITCH OUT (OFF).
  - 3.3.9 SET TRIGGERING SOURCE LINE SWITCH OUT (OFF).
  - 3.3.10 SET TRIGGERING SOURCE EXT SWITCH OUT (OFF).
  - 3.3.11 SET TRIGGERING AUTO TRIG SWITCH IN (ON).
  - 3.3.12 SET TRIGGERING AC COUPLE SWITCH OUT (DC).
  - 3.3.13 SET TRIGGERING + SLOPE SWITCH IN (+).
  - 3.3.14 SET TRIGGERING SINGLE SWP SWITCH OUT (OFF).
  - 3.3.15 SET TRIGGERING HF REJ SWITCH IN (ON).

|   |                           |          |
|---|---------------------------|----------|
|  | ARP<br>INSTRUMENTS<br>INC |          |
|   | DRAWING NO<br>81110       | REV<br>A |
| SHEET 2 OF 9  |                           |          |

## FINAL TUNE

- 3.4 ADJUST OSCILLOSCOPE INTENSITY CONTROL FOR REASONABLE TRACE BRILLIANCE.
- 3.5 ADJUST OSCILLOSCOPE FOCUS CONTROL FOR TRACE SHARPNESS.
- 3.6 READJUST TIME BASE/AMPL. POSITION CONTROL TO START TRACES AT THE LEFT GRATICULE LINE.
- 3.7 READJUST BOTH DUAL-TRACE AMPLIFIER POSITION CONTROLS TO CENTER TRACES VERTICALLY.
- 3.8 SET MODE CH 2 SWITCH OUT (OFF).
- 3.9 CONNECT DUAL BANANA TO DUAL BANANA CABLE FROM OSCILLOSCOPE CH 1 TO TEST SET OUTPUT LABELED SCOPE (OBSERVING POLARITY OF BANANA PLUGS).
- 3.10 SET TEST SET AS FOLLOWS:
  - 3.10.1 SET POWER SWITCH OFF.
  - 3.10.2 CONNECT LINE CORD TO 117 VAC.
  - 3.10.3 SET EARPHONE VOL CONTROL CCW.
  - 3.10.4 SET PEDAL CONTROL CCW.
  - 3.10.5 SET LFO SWITCH LOW.
  - 3.10.6 SET METER SELECT SWITCH BAL.
  - 3.10.7 CONNECT MONO PHONE PLUG TO DUAL BANANA CABLE ASSEMBLY TO LOW LEVEL INPUT JACKS (OBSERVING POLARITY OF BANANA PLUGS).
  - 3.10.8 CONNECT EARPHONES TO EARPHONE INPUT JACK.
  - 3.10.9 CONNECT MONO PLUG TO DUAL BANANA CABLE TO HIGH LEVEL INPUT JACKS (OBSERVING POLARITY OF BANANA PLUG).
  - 3.10.10 SET OFFSET SWITCH ON.
  - 3.10.11 SET VOLT/FREQ SWITCH TO VOLT.
  - 3.10.12 SET POWER SWITCH ON.
  - 3.10.13 CONNECT 36" BANANA TO BALL CLIP LEAD (RED) TO TEST SET JACK LABELED U.U.T. +15V.
  - 3.10.14 CONNECT 36" BANANA TO BALL CLIP LEAD (BLACK) TO TEST SET JACK LABELED U.U.T. -15V.

|   |  |                           |  |
|---|--|---------------------------|--|
|  |  | ARP<br>INSTRUMENTS<br>INC |  |
| DRAWING NO  |  | REV                       |  |
| 81119   |  | A                         |  |
| SHEET 3   |  | OF 9                      |  |

#### 4. PRELIMINARY SETUP:

- 4.1 SET POWER SWITCH ON (RED LAMP SHOULD LIGHT). INSURE THAT UNIT UNDER TEST (HEREINAFTER CALLED U.U.T.) HAS BEEN ON FOR 30 MINUTES IMMEDIATELY PRIOR TO TEST.
- 4.2 INSPECT U.U.T. FOR ELECTROMECHANICAL ASSEMBLY.
- 4.3 SET U.U.T. AS FOLLOWS:
  - 4.3.1 CONNECT LINE CORD TO APPROPRIATE A.C. VOLTAGE.
  - 4.3.2 SET PITCH BEND KNOB TO MIDPOSITION.
  - 4.3.3 SET MASTER TUNE AND VCO-2 TUNE SLIDERS TO MIDPOSITION.
  - 4.3.4 SET VCO-1 AND VCO-2 WAVEFORM MIX, VCF FREQ, LFO FREQ, AUDIO MIXER, VCA ADSR AND ADSR SUSTAIN SLIDERS UP.
  - 4.3.5 SET ALL OTHER SLIDERS DOWN.
  - 4.3.6 SET TRANSPOSE, ADSR +/-, VCO-2/RING MOD SWITCHES UP.
  - 4.3.7 SET ALL OTHER SWITCHES DOWN.
- 4.4 CONNECT MONO PHONO TO DUAL BANANA CABLE FROM TEST SET OUTPUT LABELED HI LEVEL TO U.U.T. JACK LABELED HI OUTPUT.
- 4.5 CONNECT TINY D TO TINY D FROM TEST TO U.U.T. C.V. OUT.

ALL TRIMPOTS (EXCEPT R213, POWER SUPPLY ADJUST) CAN BE REACHED THRU ACCESS HOLES ON FRONT PANEL. REFER TO TRIMPOT GUIDE ON SEPARATE SHEET FOR LOCATION OF TRIMPOTS.

#### 5. POWER SUPPLY ADJUSTMENT:

NOTE: TO PERFORM THIS ADJUSTMENT YOU MUST GAIN ACCESS TO THE BOARD BY FLIPPING THE FRONT PART OF THE PANEL UP WHILE SUPPORTING REAR PART AGAINST BACK PART OF WOODEN CAB. BE SURE TO AVOID TOUCHING AREA OF BOARD WHERE POWER SUPPLY IS LOCATED (SAME AREA AS TRANSFORMER). LIVE A.C. IS PRESENT AT POWER SWITCH AND POWER TERMINALS.

- 5.1 CONNECT RED BALL CLIP LEAD FROM TEST SET OUTPUT LABELED U.U.T. +15V TO U.U.T. T.P. 14
- 5.2 CONNECT BLACK BALL CLIP LEAD FROM TEST SET OUTPUT LABELED U.U.T. -15V TO U.U.T. T.P. 15
- 5.3 ADJUST R213 UNTIL METER INDICATES IN BLACK ZONE
- 5.4 REMOVE RED BALL CLIP FROM TP14 AND BLACK BALL CLIP FROM TP15.
- 5.5 FLIP PANEL DOWN TO ITS ORIGINAL PLACE.

## 6. KEYBOARD CV, PITCH BEND AND TRANSPOSE ADJUST:

- 6.1 SET METER SELECT TO C1-OCV.
- 6.2 DEPRESS AND WEDGE C1
- 6.3 ADJUST OFFSET ON SYSTEM TESTER UNTIL METER INDICATES IN BLACK ZONE.
- 6.4 RELEASE C1
- 6.5 DEPRESS AND WEDGE C4.
- 6.6 SET METER SELECT TO 3CV-C4.
- 6.7 ADJUST R43 UNTIL METER INDICATES IN BLACK ZONE.
- 6.8 RELEASE C4.
- 6.9 REPEAT STEPS 6.1 TO 6.8 UNTIL NO FURTHER ADJUSTMENTS ARE NECESSARY.
- 6.10 SET METER SELECT TO 4CV-C5.
- 6.11 DEPRESS AND WEDGE C4.
- 6.12 SET PITCH BEND KNOB CLOCKWISE.
- 6.13 ADJUST R9 UNTIL METER INDICATES IN BLACK ZONE.
- 6.14 SET METER SELECT TO 2CV-C3.
- 6.15 SET PITCH BEND KNOB COUNTERCLOCKWISE.  
METER SHOULD INDICATE WITHIN  $\pm 30$  ON SCALE.
- 6.16 SET METER SELECT TO 3CV-C4.
- 6.17 ADJUST PITCH BEND KNOB UNTIL METER INDICATES IN BLACK ZONE.
- 6.18 SET METER SELECT TO 1CV-C2.
- 6.19 SET TRANSPOSE SWITCH TO DOWN 1 OCTAVE.
- 6.20 ADJUST R1 UNTIL METER INDICATES IN BLACK ZONE
- 6.21 SET TRANSPOSE SWITCH TO UP 1 OCTAVE.
- 6.22 RELEASE C4.

## 7. VCO-1 CALIBRATION:

- 7.1 SET TEST SET VOLT/FREQ METER SWITCH DOWN TO FREQ.
- 7.2 SET METER SELECT TO 1CV-C2.
- 7.3 DEPRESS AND HOLD C1.
- 7.4 ADJUST R62 UNTIL METER INDICATES IN BLACK ZONE.
- 7.5 RELEASE C1.
- 7.6 DEPRESS AND HOLD C4.
- 7.7 SET METER SELECT TO 4CV-C5.
- 7.8 ADJUST R56 UNTIL METER INDICATES IN BLACK ZONE.
- 7.9 RELEASE C4.
- 7.10 REPEAT STEPS 7.2 TO 7.9 UNTIL NO FURTHER ADJUSTMENT IS NECESSARY.
- 7.11 SET VCO-1 WAVEFORM MIX SLIDER DOWN.
- 7.12 DEPRESS AND WEDGE C1.
- 7.13 SET SCOPE TIME BASE CAL (RED KNOB) COUNTER-CLOCKWISE UNTIL 1 FULL WAVEFORM IN 10 HORIZ. DIV. IS OBTAINED.
- 7.14 ADJUST R76 UNTIL A 50% PULSE WIDTH OF THE SQUAREWAVE ON SCOPE IS OBTAINED.

## 8. VCO-2 CALIBRATION:

- 8.1 SET AUDIO MIXER SLIDER DOWN TO VCO-2.
- 8.2 SET METER SELECT TO 1CV-C2 (C1 SHOULD STILL BE WEDGED).
- 8.3 ADJUST R100 UNTIL METER INDICATES IN BLACK ZONE.
- 8.4 RELEASE C1.
- 8.5 DEPRESS AND HOLD C4.
- 8.6 SET METER SELECT TO 4CV-C5.
- 8.7 ADJUST R93 UNTIL METER INDICATES IN BLACK ZONE.
- 8.8 RELEASE C4.
- 8.9 REPEAT STEPS 8.2 TO 8.8 UNTIL NO FURTHER ADJUSTMENTS ARE NECESSARY.

- 8.10 SET VCO-2 WAVEFORM MIX DOWN.
- 8.11 READJUST TIME BASE CAL (RED KNOB) TO OBTAIN ONE FULL WAVEFORM ON SCOPE.
- 8.12 DEPRESS AND WEDGE C1.
- 8.13 ADJUST R112 UNTIL A 50% PULSE WIDTH OF THE SQUAREWAVE ON SCOPE IS OBTAINED.

## 9. VCF CALIBRATION:

- 9.1 INSTALL DUMMY PHONE PLUG INTO EXT AUDIO IN JACK
  - 9.2 SET VCF FREQ SLIDER DOWN.
  - 9.3 SET VCF RESONANCE SLIDER UP.
  - 9.4 SET VCO-2/RING MOD SWITCH DOWN (EXT IN).
  - 9.5 SET TIME BASE CAL (RED KNOB) FULLY CLOCKWISE.
  - 9.6 SET SCOPE SEC/DIV. TO 10m AND CH. 1 VOLTS/DIV. TO .2.
  - 9.7 ADJUST R141 FOR 1 FULL WAVEFORM OF SINEWAVE ON SCOPE IN 6.25 HORIZONTAL DIVISIONS.
  - 9.8 SET METER SELECT TO 1CV-C2.
  - 9.9 SET VCF KYBD CV SLIDER UP.
  - 9.10 SET VCF FREQ SLIDER UP UNTIL METER INDICATES IN BLACK ZONE
  - 9.11 RELEASE C1.
  - 9.12 DEPRESS AND WEDGE C4.
  - 9.13 SET METER SELECT TO 4CV-C5.
  - 9.14 ADJUST R134 UNTIL METER INDICATES IN BLACK ZONE.
  - 9.15 REPEAT STEPS 9.8 TO 9.14 UNTIL NO FURTHER ADJUSTMENT ARE NECESSARY.
- NOTE: WHEN REPEATING STEPS 9.8 TO 9.14, BEFORE READJUSTING VCF FREQ SLIDER WAIT FOR METER TO STOP DRIFTING; IT MAY DRIFT INTO BLACK ZONE.
- 9.16 WEDGE DOWN C4.



## 10. VCA AND VCF CVR ADJUSTMENTS :

- 10.1 SET VCF FREQ, VCF RESONANCE, KYBD CV AND ADSR SUSTAIN SLIDERS DOWN.
- 10.2 SET TRIGGER SWITCH UP (AUTO).
- 10.3 SET SCOPE VOLTS/DIV TO 50m.
- 10.4 WEDGE DOWN C4.
- 10.5 ADJUST R198 FOR MINIMUM WAVEFORM ON SCOPE (1 VERTICAL DIV. MAX).
- 10.6 SET VCF ADSR SLIDER UP.
- 10.7 ADJUST R151 FOR MINIMUM WAVEFORM (2 VERTICAL DIVISIONS MAXIM)
- 10.8 REMOVE WEDGE FROM C4.

## 11. SHUTDOWN:

- 9.1 SET POWER SWITCH OFF.
- 9.2 REMOVE LINE CORD FROM A.C. VOLTAGE.
- 9.3 REMOVE ALL CABLES FROM U.U.T.
- 9.4 MARK U.U.T. WITH PROPER DISPOSTION.